

- CIRCUITO FRIGORIFERO ALTA PRESSIONE / HIGH PRESSURE REFRIGERANT CIRCUIT
- CIRCUITO FRIGORIFERO BASSA PRESSIONE / LOW PRESSURE REFRIGERANT CIRCUIT
- CIRCUITO IDRAULICO ACQUA CALDA / HYDRAULIC CIRCUIT WARM WATER
- CIRCUITO IDRAULICO ACQUA FREDDA / HYDRAULIC CIRCUIT COLD WATER
- LINEA DEI EQUALIZZAZIONE DELL'OLIO / EQUALISATION LINE OF OIL

LEGENDA /
LEGEND

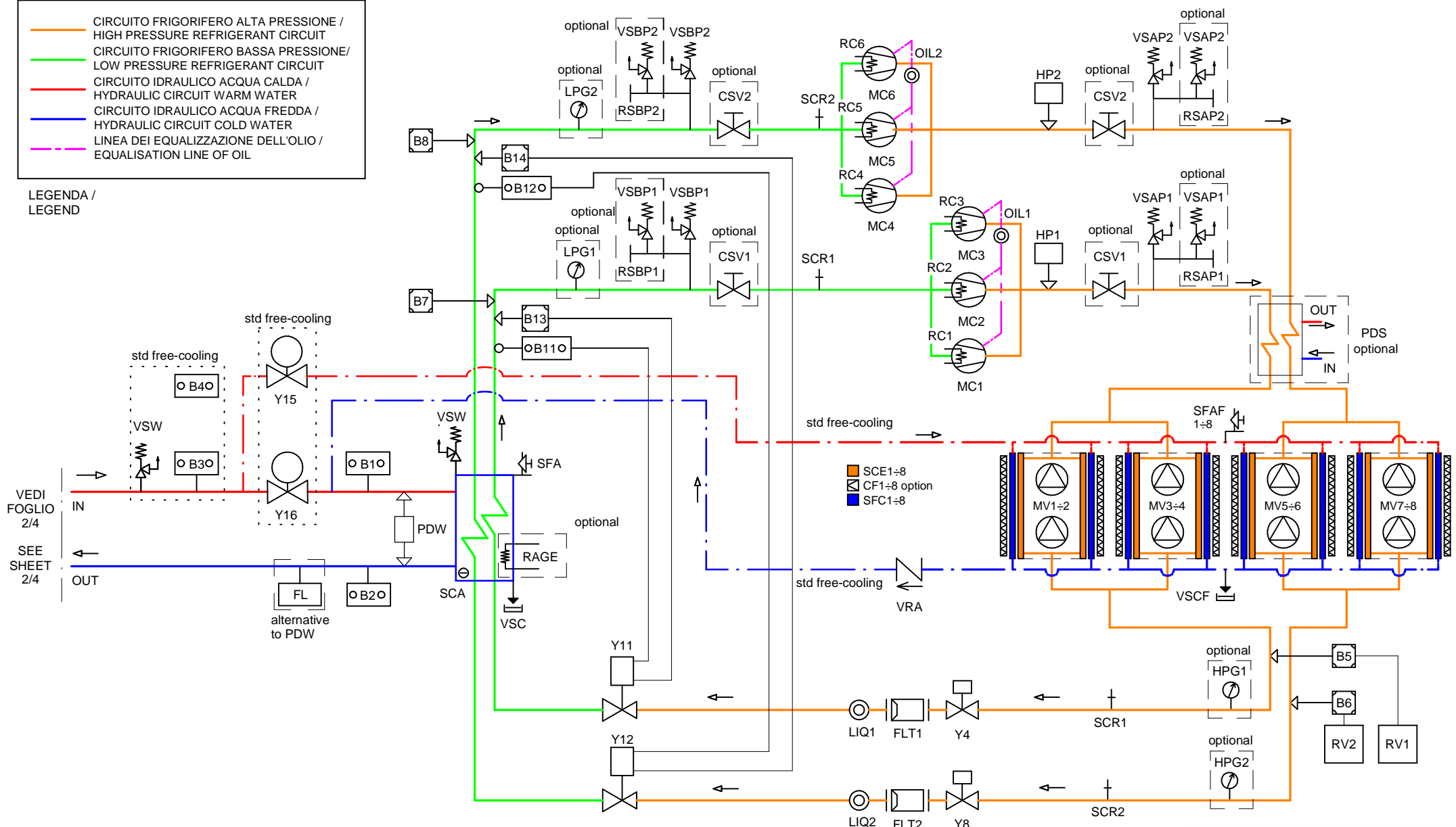

Scala-Scale	Data-Date 29/09/2016	Dis.to-Drawn T.F.	Ver.-Version
Peso-Weight Kg	Materiali-Materials		
Denominazione-Denomination SBS.530-660 (IC208CX)/SBSF.470 (pCO5 control)			
Particolare-Detail SCHEMA FRIGORIF./IDRAULICO HYDRAULIC/REFRIGERATING DIAGRAM			
FOGLIO/SHEET 1/4			
DIS.-DRAW N.		SFI-SBS-530ST01	
REVISIONE		00	
PROGRAM. N.			

— HYDRAULIC CIRCUIT WARM WATER
 CIRCUITO IDRAULICO ACQUA FREDDA /
— HYDRAULIC CIRCUIT COLD WATER

LEGENDA /
 LEGEND

CON SERBATOIO - CON POMPA /
 WITH TANK - WITH PUMP

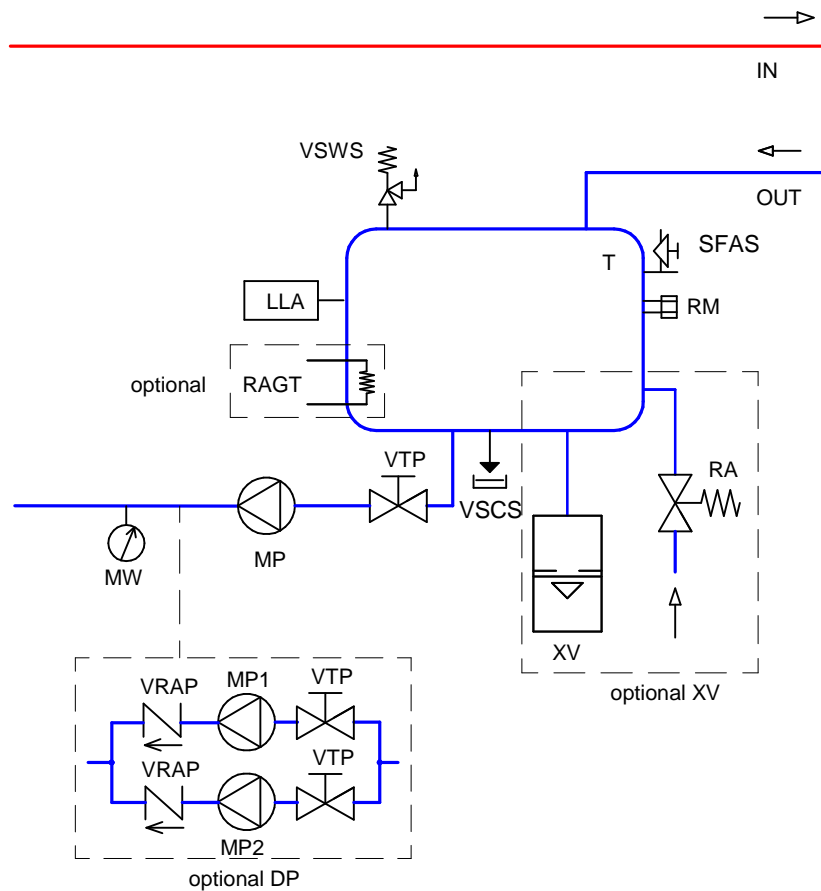

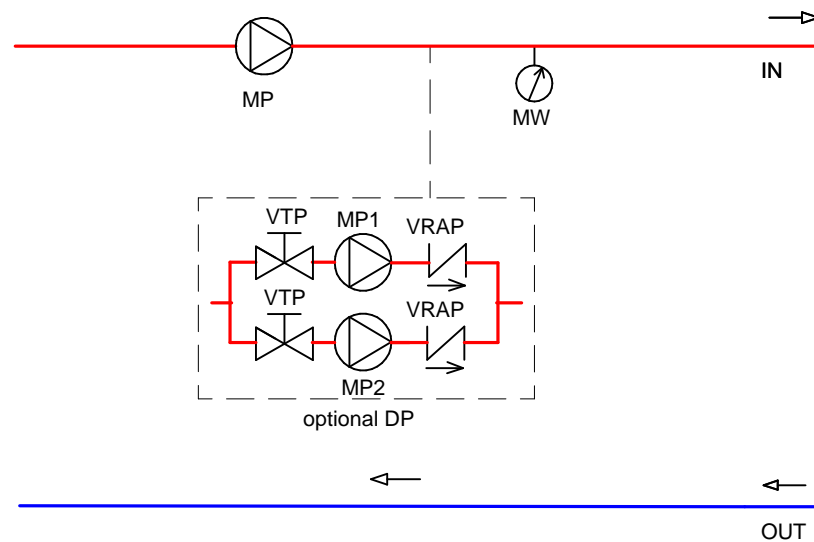

SENZA SERBATOIO - CON POMPA /
 WITHOUT TANK - WITH PUMP



Scala-Scale	Data-Date 29/09/2016	Dis.to-Drawn T.F.	Ver.-Version	
Peso-Weight Kg	Materiali-Materials			
Denominazione-Denomination SBS.530-660 (IC208CX)/SBSF.470 (pCO5 control)				DIS.-DRAW N. SFI-SBS-530ST01
Particolare-Detail SCHEMA FRIGORIF./IDRAULICO HYDRAULIC/REFRIGERATING DIAGRAM				REVISIONE 00
FOGLIO/SHEET 2/4				PROGRAM. N.

CIRCUITO IDRAULICO / HYDRAULIC CIRCUIT			
SIGLA / SIGN	DESCRIZIONE	DESCRIPTION	NOTE
VSW	VALVOLA DI SICUREZZA ACQUA	WATER RELIEF VALVE	std free cooling
B3	SENSORE TEMPERATURA ACQUA INGRESSO FREE COOLING	FREE COOLING INLET WATER TEMPERATURE SENSOR	std free cooling
Y16	VALVOLA 2 VIE EVAPORATORE	EVAPORATOR 2 WAY VALVE	std free cooling
B1	SENSORE TEMPERATURA ACQUA INGRESSO EVAPORATORE	EVAPORATOR INLET WATER TEMPERATURE SENSOR	std
SCA	SCAMBIATORE DI CALORE AD ACQUA (EVAPORATORE A FASCIO TUBIERO)	WATER HEAT EXCHANGER (SHELL & TUBE EVAPORATOR)	std
SFA	SFIATO DELL'ARIA MANUALE EVAPORATORE	EVAPORATOR MANUAL AIR VENT	std
VSC	VALVOLA DI SCARICO ACQUA EVAPORATORE	EVAPORATOR WATER DISCHARGE VALVE	std
VSCW	VALVOLA DI SICUREZZA EVAPORATORE	EVAPORATOR RELIEF VALVE	std
RAGE	RESISTENZA ANTIGELO EVAPORATORE	EVAPORATOR ANTIFREEZE HEATER	optional
B2	SENSORE TEMPERATURA ACQUA USCITA EVAPORATORE	EVAPORATOR OUTLET WATER TEMPERATURE SENSOR	std
PDW	PRESSOSTATO DIFFERENZIALE	DIFFERENTIAL PRESSURE SWITCH	std for SBS
FL	FLUSSOSTATO	FLOW SWITCH	std for SBSF, alternative to PDW for SBS.
Y15	VALVOLA A DUE VIE FREE COOLING	FREE COOLING 2-WAYS VALVE	std free cooling
SFC1÷10	SCAMBIATORE DI CALORE ARIA-ACQUA (FREE COOLING)	AIR-WATER HEAT EXCHANGER (FREE COOLING)	std free cooling
SFA1÷10	SFIATO DELL'ARIA MANUALE FREE COOLING	FREE COOLING MANUAL AIR VENT	std free cooling
VSCF	VALVOLA DI SCARICO ACQUA FREE COOLING	FREE COOLING WATER DISCHARGE VALVE	std free cooling
VRA	VALVOLA DI NON RITORNO FREE COOLING	FREE COOLING CHECK VALVE	std free cooling
T	SERBATOIO DI ACCUMULO	STORAGE TANK	optional
RM	TAPPO DI RIEMPIMENTO MANUALE	MANUAL FILLING CAP	optional (included in the T option)
VSW	VALVOLA DI SICUREZZA SERBATIO	TANK SAFETY VALVE	optional (included in the T option)
VSCS	VALVOLA DI SCARICO ACQUA DEL SERBATOIO	DISCHARGE WATER VALVE FOR TANK	optional (included in the T option)
SFAS	SFIATO ARIA SERBATIO	AIR VENT FOR TANK	manual for std (automatic with XV option)
LLA	ALLARME BASSO LIVELLO ACQUA	ELECTRIC FLOAT LOW LEVEL ALARM	optional (included in the T option)
RAGT	RESISTENZA ANTIGELO VASCA	ANTIFREEZE HEATER INERTIAL TANK	optional
XV	VASO DI ESPANSIONE	EXPANSION VESSEL	optional (included in the XV option)
RA	RIEMPIMENTO AUTOMATICO CON VALVOLA DI RITEGNO E FILTRO	AUTOMATIC FEEDER WITH CHECK VALVE AND FILTER INCORPORATED	optional (included in the XV option)
MP	ELETTROPOMPA DI PROCESSO	PROCESSING PUMP	optional (included in the option WP,PH)
MW	MANOMETRO ACQUA	WATER PRESSURE GAUGE	optional (included in the option WP,PH)
VTP	VALVOLA DI INTERCETTAZIONE TRA VASCA E POMPA	SHUT OFF VALVE BETWEEN TANK AND PUMP	optional (included in the option WP,PH)
MP1-MP2	ELETTROMPA DI PROCESSO	PROCESSING PUMP	optional (included in the option DP,DPH)
VRAP	VALVOLA DI NON RITORNO ACQUA	NO RETURN WATER VALVE	optional (included in the option DP,DPH)



ALTRO / OTHER			
SIGLA / SIGN	DESCRIZIONE	DESCRIPTION	NOTE
B4	SENSORE TEMPERATURA AMBIENTE	AMBIENT TEMPERATURE SENSOR	std

	CIRCUITO IDRAULICO ACQUA CALDA / HYDRAULIC CIRCUIT WARM WATER
	CIRCUITO IDRAULICO ACQUA FREDDA / HYDRAULIC CIRCUIT COLD WATER

LEGENDA /
LEGEND

Scala-Scale	Data-Date 29/09/2016	Dis.to-Drawn T.F.	Ver.-Version	 cool with HITEMA international hitema.com	
Peso-Weight Kg	Materiali-Materials				
Denominazione-Denomination SBS.530-660 (IC208CX)/SBSF.470 (pCO5 control)				DIS-DRAW N.	SFI-SBS-530ST01
Particolare-Detail SCHEMA FRIGORIF./IDRAULICO HYDRAULIC/REFRIGERATING DIAGRAM				REVISIONE	00
FOGLIO/SHEET 3/4				PROGRAM. N.	

CIRCUITO FRIGORIFERO / REFRIGERATING CIRCUIT (TAB 1/2)				
SIGLA / SIGN	DESCRIZIONE	DESCRIPTION	NOTE	
MC1÷6	COMPRESSORE	COMPRESSOR	std	
RC1÷6	RESISTENZA CARTER COMPRESSORE	COMPRESSOR CRANKCASE HEATER	std	
OIL1÷2	SPIA DI FLUSSO OLIO	OIL SIGHT GLASS	std	
HP1÷2	PRESSOSTATO ALTA PRESSIONE	HIGH PRESSURE SWITCH	std	
CSV1÷2	VALVOLA DI INTERCETTAZIONE COMPRESSORE	COMPRESSOR SHUT OFF VALVE	std	
VSAP1÷2	VALVOLA DI SICUREZZA ALTA PRESSIONE	HIGH PRESSURE RELIEF VALVE	std	
RSAP1÷2	VALVOLA DI COMMUTAZIONE ALTA PRESSIONE	HIGH PRESSURE CHANGEOVER VALVE	optional	
SCR1÷2	VALVOLA DI CARICO SCHRADER	CHARGE VALVE (SCHRADER)	std	
PDS	RECUPERATORE DI CALORE PARZIALE	PARTIAL HEAT RECOVER	optional	
SCE1÷8	SCAMBIATORE DI CALORE AD ARIA (CONDENSATORE)	AIR HEAT EXCHANGER (CONDENSER)	std	
SFAF1÷8	SFIATO ARIA MANUALE FREE COOLING	FREE COOLING MANUAL AIR VENT	std	
CF1÷8	FILTRO ARIA CONDENSATORE IN ALLUMINIO	CONDENSER AIR ALUMINUM FILTER	optional	
MV1÷8	MOTOVENTILATORE ASSIALE	AXIAL FAN	std AC fans (optional EC fans)	
B5÷6	TRASDUTTORE ALTA PRESSIONE	HIGH PRESSURE TRASDUCER	std	
RV1÷2	REGOLATORE DI VELOCITA' VENTILATORI A INVERTER	INVERTER FAN SPEED REGULATOR	std	
HPG1÷2	MANOMETRO ALTA PRESSIONE	HIGH PRESSURE GAUGE	optional	
SCR1÷2	VALVOLA DI CARICO SCHRADER	CHARGE VALVE (SCHRADER)	std	
Y4, Y8	VALVOLA SOLENOIDE LINEA DEL LIQUIDO	LIQUID LINE SOLENOID VALVE	std	
FLT1÷2	FILTRO DISIDRATATORE	DEHYDRATING FILTER	std	
LIQ1÷2	SPIA DI FLUSSO	SIGHT GLASS	std	
Y11÷12	VALVOLA DI ESPANSIONE ELETTRONICA	ELECTRONIC EXPANSION VALVE	std	
SCA	SCAMBIATORE DI CALORE AD ACQUA (EVAPORATORE A FASCIO TUBIERO)	WATER HEAT EXCHANGER (SHELL & TUBE EVAPORATOR)	std	
B11÷12	SENSORE TEMPERATURA ASPIRAZIONE COMPRESSORE	SUCTION COMPRESSOR TEMPERATURE SENSOR	std	
B13÷14	TRASDUTTORE BASSA PRESSIONE PER LA VALVOLA DI ESPANSIONE	LOW PRESSURE TRASDUCER FOR THE EXPANSION VALVE	std	
B7÷8	TRASDUTTORE BASSA PRESSIONE	LOW PRESSURE TRASDUCER	std	
LPG1÷2	MANOMETRO BASSA PRESSIONE	LOW PRESSURE GAUGE	optional	
VSBP1÷2	VALVOLA DI SICUREZZA BASSA PRESSIONE	LOW PRESSURE RELIEF VALVE	std	
RSBP1÷2	VALVOLA DI COMMUTAZIONE BASSA PRESSIONE	LOW PRESSURE CHANGEOVER VALVE	optional	
CSV1÷2	VALVOLA DI INTERCETTAZIONE COMPRESSORE	COMPRESSOR SHUT OFF VALVE	optional	
SCR1÷2	VALVOLA DI CARICO SCHRADER	CHARGE VALVE (SCHRADER)	std	
LP1÷2	PRESSOSTATO BASSA PRESSIONE	LOW PRESSURE SWITCH	std	

	CIRCUITO FRIGORIFERO ALTA PRESSIONE / HIGH PRESSURE REFRIGERANT CIRCUIT
	CIRCUITO FRIGORIFERO BASSA PRESSIONE / LOW PRESSURE REFRIGERANT CIRCUIT
	LINEA DEI EQUALIZZAZIONE DELL'OLIO / EQUALISATION LINE OF OIL

LEGGENDA /
LEGEND

Scala-Scale	Data-Date 29/09/2016	Dis.to-Drawn T.F.	Ver.-Version		
Peso-Weight Kg	Materiali-Materials				
Denominazione-Denomination SBS.530-660 (IC208CX)/SBSF.470 (pCO5 control)				DIS.-DRAW N.	SFI-SBS-530ST01
Particolare-Detail SCHEMA FRIGORIF./IDRAULICO HYDRAULIC/REFRIGERATING DIAGRAM				REVISIONE	00
FOGLIO/SHEET 4/4				PROGRAM. N.	